

REVISIONS			
REV	DESCRIPTION	DATE	APPROVED

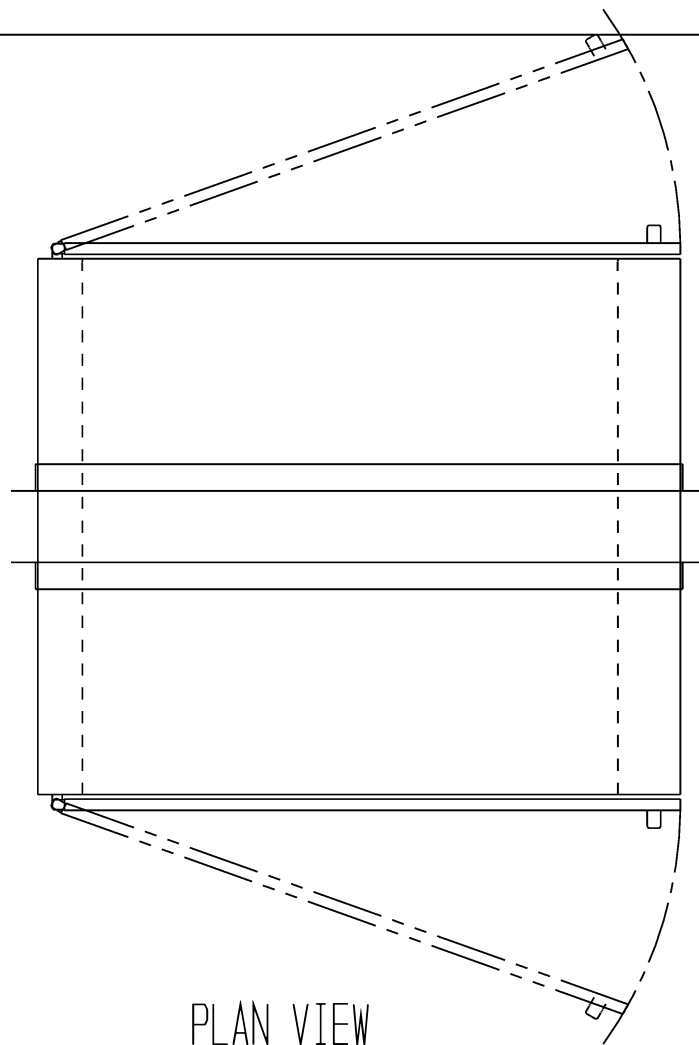

PLAN VIEW

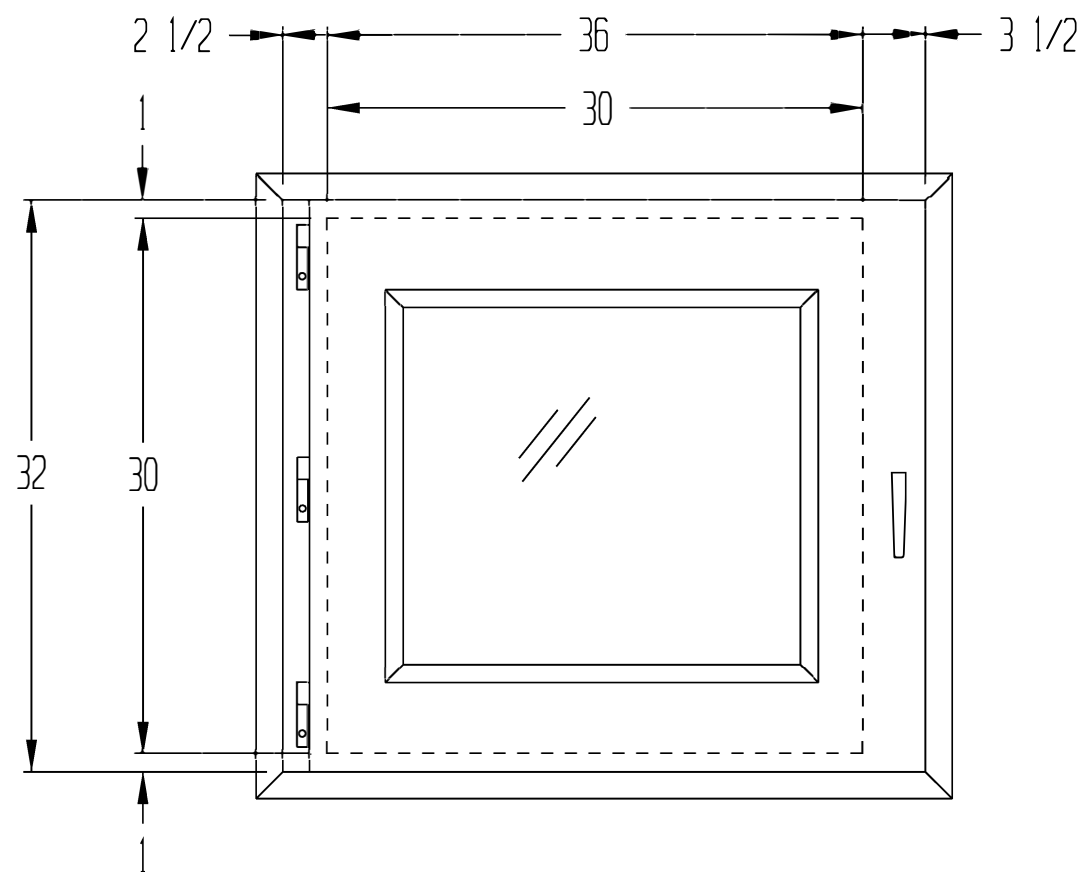

FRONT VIEW

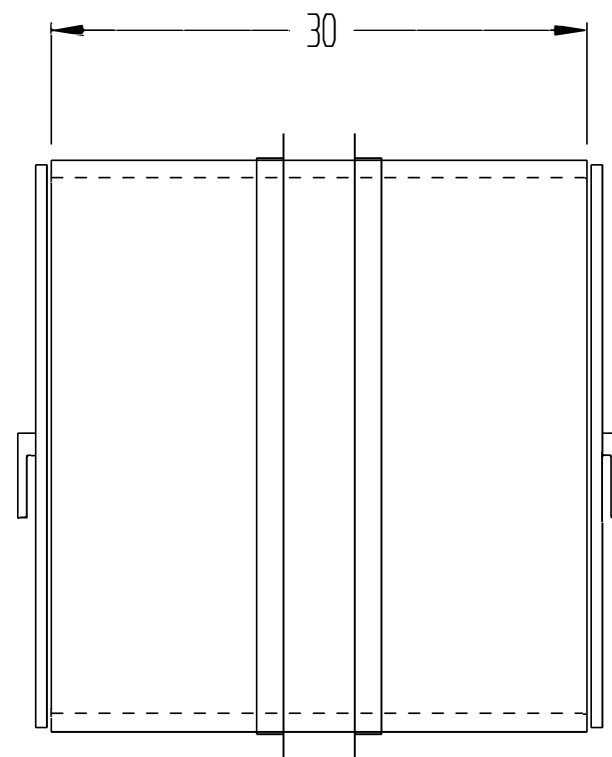

SIDE VIEW

NOTES:

- UNIT FABRICATION TO BE DOUBLE WALL, CONSTRUCTION
- UNIT TO BE CONSTRUCTED OF 20 GA. 304 STAINLESS STEEL WITH #4 FINISH.
- DOORS TO BE CONSTRUCTED OF 304 STAINLESS STEEL WITH 1/4" THK. CLEAR ACRYLIC WINDOWS, BULLET HINGES AND QUARTER TURN HANDLES
- UNIT TO BE SUPPLIED WITH 1 1/2" X 1 1/2" X 16 GA. 304 STAINLESS STEEL MOUNTING ANGLE & BOTTOM ANGLE BRACETS (TO BE FIELD INSTALLED)
- UNIT TO HAVE A MECHANICAL DOOR INTERLOCK SYSTEM
- UNIT PROVIDED W/ (2) SOLID SS SHELVES & ADJUSTABLE TRACK
- ROUGH OPENING TO BE 1/4" LARGER THAN OUTSIDE DIMENSIONS OF UNIT

DRAWN FOR		<b>HALCO PRODUCTS CO.</b>			
		100 NO. GORDON STREET ELK GROVE, IL. 60007			
		TITLE PASS THRU MODEL #PT3030-30 MI/SS			
DRAWN BY	TM	SIZE	JOB NO. 12019	DWG NO. 1515193B0	REV
APPROVED BY		SCALE 1"=1'-0"	DATE 7-15-08	SHEET	