

REVISIONS			
REV	DESCRIPTION	DATE	APPROVED

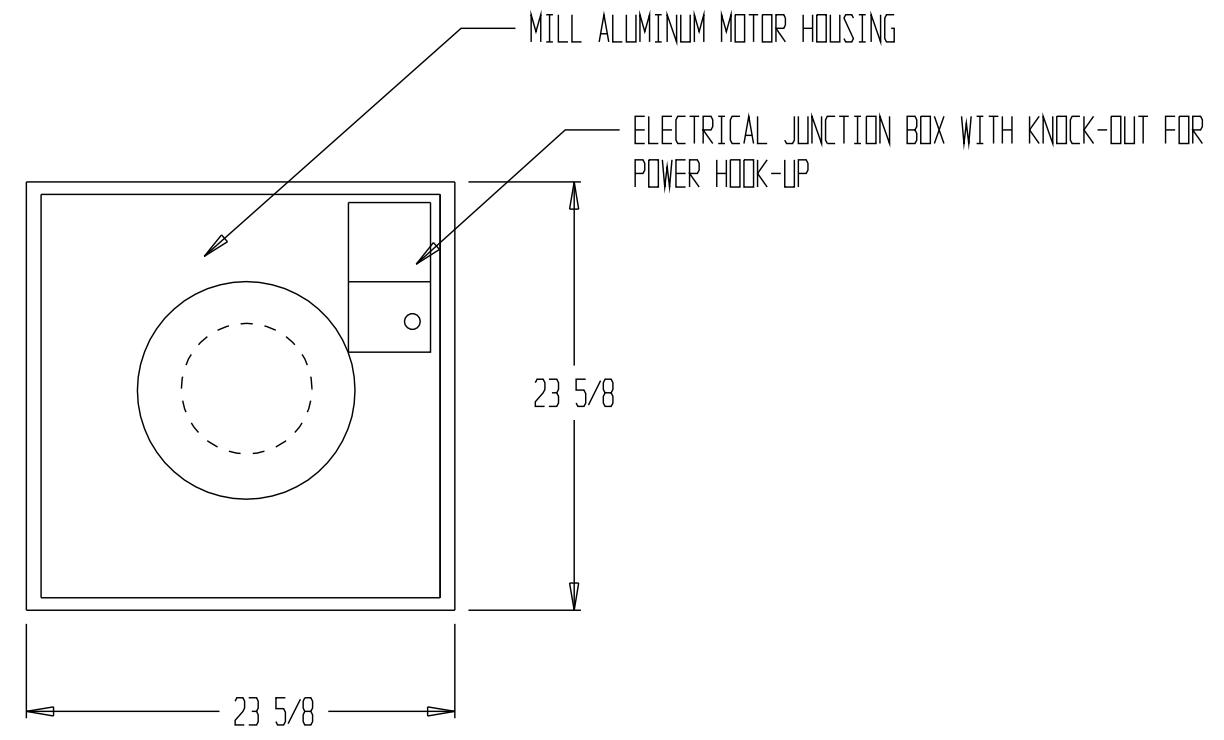

- NOTES:
- ELECTRICAL TO MEET LATEST NEC CODES
 - UNIT TO BE CAPABLE OF PRODUCING 120 FPM (MAX.) OF AIR @ 6" FROM FILTER FACE
 - ELECTRICAL REQUIREMENT: 115V, 1 PHASE, 240W
 - UNIT ROOMSIDE SEVICABLE
 - UNIT WEIGHT 50 LBS
 - PROVIDED WITH 10' POWER CORD & PLUG

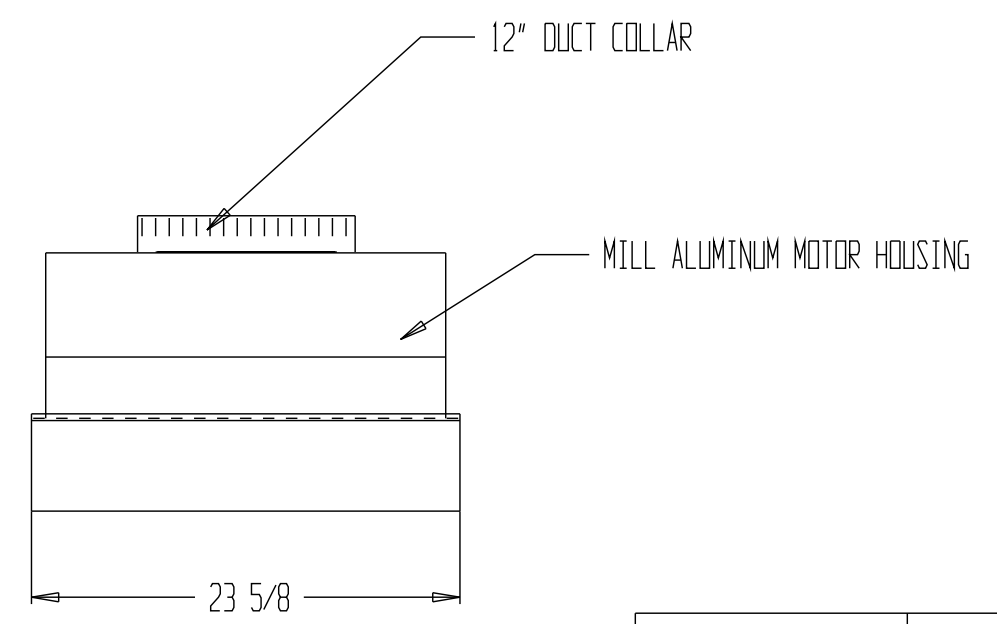
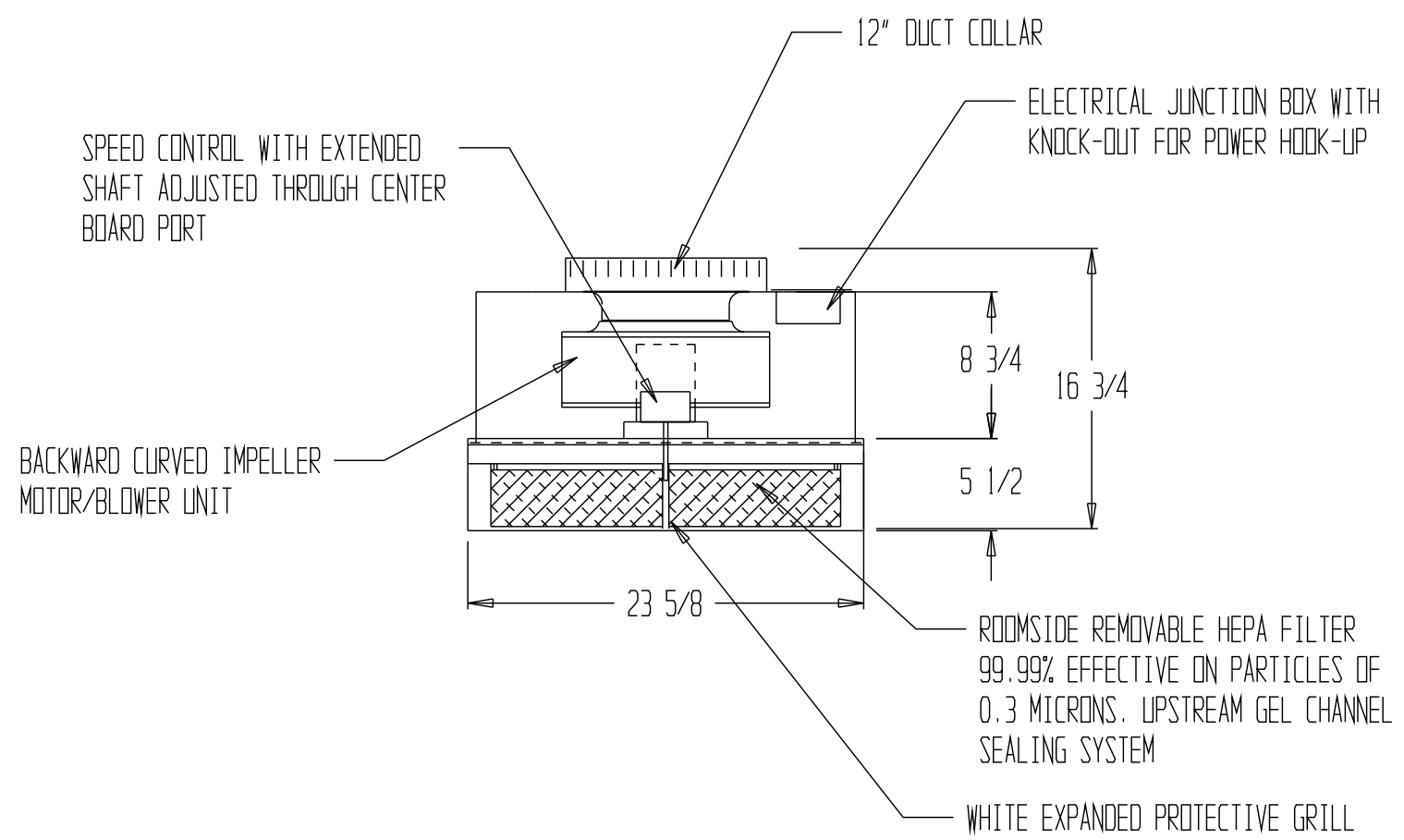

DRAWN FOR		HALCO PRODUCTS CO.		
ROBERT BOSCH CORP ANDERSON, SC		100 NO. GORDON STREET ELK GROVE, IL. 60007		
		TITLE AT2000-441300 FAN FILTER UNIT		
DRAWN BY	TM	SIZE	JOB NO. SJ449	DWG NO. 1718083B0
APPROVED BY		SCALE	DATE	SHEET
		1"=1'	2-25-14	