



# HALCO PRODUCTS COMPANY

100 N. Gordon St. Elk Grove Village, IL 60007-1193  
Phone (847) 956-1600 Fax (847) 956-0595  
E-mail: info@halco-products.com  
Website: www.halco-products.com

Date: 5/24/2021  Denotes the default choice \* Denotes an optional field

Customer: \_\_\_\_\_  
\_\_\_\_\_  
\_\_\_\_\_

Ship To: \_\_\_\_\_  
\_\_\_\_\_  
\_\_\_\_\_

TAG/P.O. #: \_\_\_\_\_

Project #: \_\_\_\_\_

\* Unit #: \_\_\_\_\_ \* Model: \_\_\_\_\_ \* S/N # \_\_\_\_\_

**Volt:**  480 V  **Phase:**  3  **Hertz:**  60   
 Other: \_\_\_\_\_  Other: \_\_\_\_\_  Other: \_\_\_\_\_  
 Explosion-Resistant Class: \_\_\_ Div. \_\_\_ Grp. \_\_\_

**Material of Construction:** \_\_\_\_\_  
 16 Ga. Galv.  Knocked Down Const.  
 Unpainted   Painted:  
 White  Other: \_\_\_\_\_  
 304 Stainless Steel  316 Stainless Steel  
 No Silicone

**Floor Design:**  
 No Floor   
 Raised 6" Grated Floor

\* **Ionizing Anti-Static Grid:**  
 Anti-Static Bars and Power Supply

\* **Tunnel Design Option:**  
Length: \_\_\_\_\_  
 Optional Cooling: \_\_\_\_\_ Tons

**Special Design Construction:**  
\_\_\_\_\_  
\_\_\_\_\_  
\_\_\_\_\_

\* **Disconnect:**  
 Fused  Non-Fused   
Location: \_\_\_\_\_  
Type: \_\_\_\_\_

**Doors:**  Aluminum   Stainless Steel  
 30" Wide  36" Wide   Other  
 1/2 Glazing 1/2 Solid on Bottom  
 Safety Plate Glazing  
 3 Door Option Specify Location  
 Fire Rated \_\_\_\_\_ Hour(s)  
 Window  No Window  
 Motorized Bi-Parting  
 Roll-Up

**Motor:** HP: \_\_\_\_\_ RPM: \_\_\_\_\_ Frame: \_\_\_\_\_  
Qty\* \_\_\_\_\_ Blower: \_\_\_\_\_ \* Are you aware that each blower requires 2 access doors?

**Nozzles:** Qty.: \_\_\_\_\_ Size \_\_\_\_\_  
\* **Ceiling Purge HEPA Blower**  
 99.97%  ULPA  
HP: \_\_\_\_\_ CFM: \_\_\_\_\_

**Control Panel**  
 Inside Blower Module  
 External Remote  
NEMA: \_\_\_\_\_ Labeled: \_\_\_\_\_

PLC   Remote Panel  
\* **Magnehelic Filter Status Gauges**  
 Prefilter  HEPA  
 Including Signal Flag  
 Photohelic With Alarm Qty: 1 \* Qty: 2

\* **Sprinkler Head**  
 1" Pipe Rough in Opening Only

**Configuration**  
 Straight Thru   
 90° Right L  90° Left L  
 Cart Pass Thru Design

\* **Low Head Room**  
 Side Mount Blower  
 Left Side  Right Side

\* **Spare Prefilters & HEPA Filters**  
Prefilters \_\_\_\_\_ Cartons (of 12)  
HEPAs  99.97%  ULPA Qty: \_\_\_\_\_

DOOR	HINGE		NO DOOR NOTE #1	SWING		SPECIAL
	LEFT	RIGHT		IN	OUT	
1						
2						
3						

Products for the HVAC and Clean Room Industry  
Visit our WEBSITE at  
[www.halco-products.com](http://www.halco-products.com)

100 N. Gordon St. Elk Grove Village, IL 60007-1193  
 Phone (847) 956-1600 Fax (847) 956-0595  
 E-mail: [info@halco-products.com](mailto:info@halco-products.com)  
 Website: [www.halco-products.com](http://www.halco-products.com)

Please circle your desired door swings, access doors (2 required for each blower motor), and electric disconnect locations:

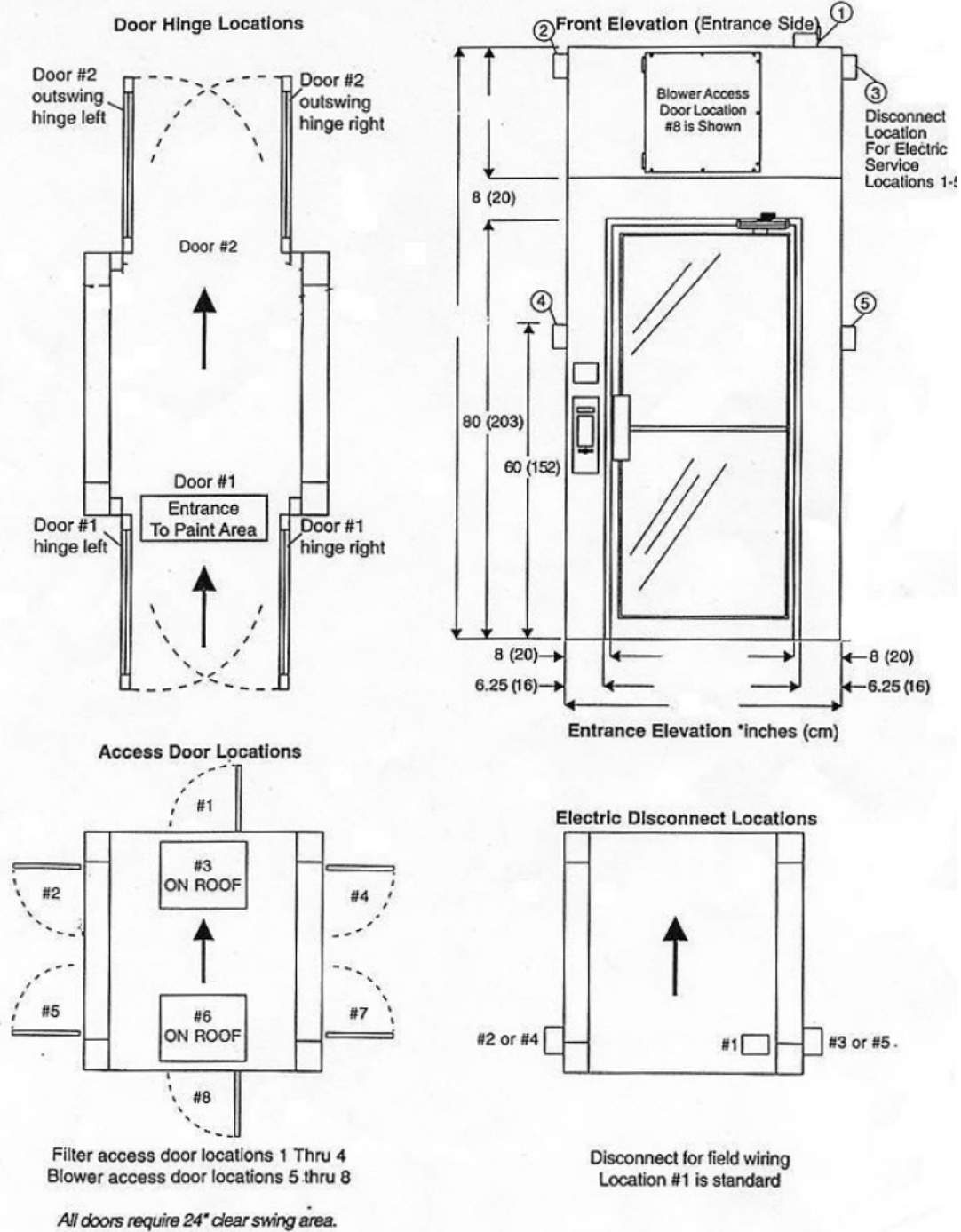

Products for the HVAC and Clean Room Industry  
 Visit our WEBSITE at  
[www.halco-products.com](http://www.halco-products.com)