



HALCO PRODUCTS COMPANY

100 N. Gordon Street - Elk Grove Village, IL 60007-1193

Tel: 847-956-1600 - Fax: 847-956-0595

E-Mail: Info@Halco-Products.com

Website: www.Halco-Products.com

HALCO
PRODUCT
INFORMATION

400.8000

HORIZONTAL MODULES

Halco Laminar Flow Wall Modules are standard units providing a simple and economical supply of sterile air to a critical area.

Uses Include:

- Horizontal Laminar Flow Tunnels
- Clean rooms
- For upgrading existing facilities
- For new contamination control requirements.

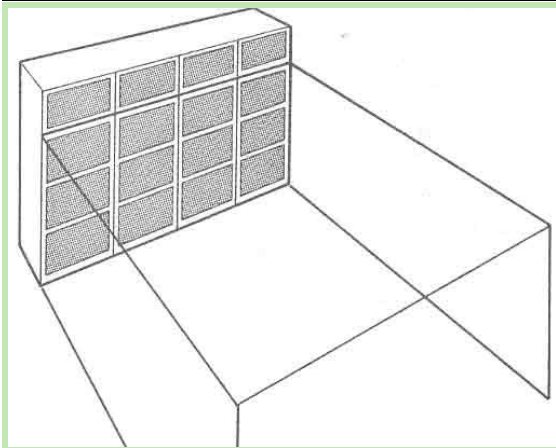

Wall modules will provide class 100 conditions as specified in Federal Standard 209E, ISO, and Air Force Technical Order 00-25-203.

SPECIFICATIONS



TYPICAL COMPONENTS:

1. Shook-mounted blower assembly
2. Blower enclosure
3. Hepa filter bank
4. Alternate blower enclosure location
5. Air inlet with disposable prefilter
6. Removable anodized aluminum protective grille
7. Alternate prefilter location

OPTIONS:

Construction:

- Laminated Particle Board Painted Steel
- 304 S/S 316 S/S

HEPA'S:

- Front Load Rear Load
- 99.97% EFF 99.97% EFF ULPA

Electrical:

- 115/1/60 208/230/1/60 460/3/60

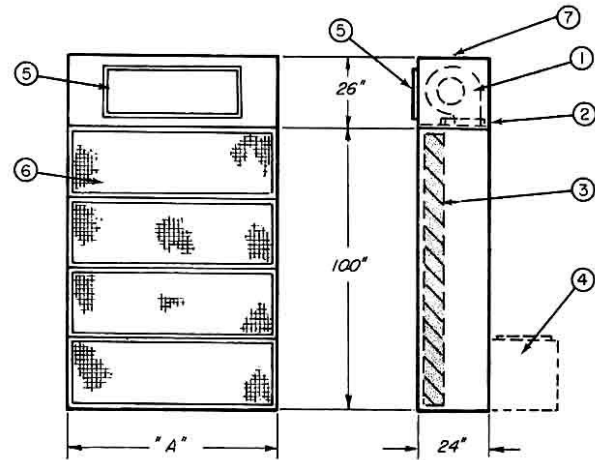

HOUSING:

Particle board laminated with plastic (Formica or equal) or optional epoxy painted CRS. or Stainless Steel.

INTERIOR:

Sealed with grey vinyl to prevent flaking.

BLOWER:

Continuous duty direct drive motors & permanently lubricated bearings

SUPER INTERCEPTION GRILLE:

Perforated anodized aluminum.

PRE-FILTER:

Disposable polyester 35% efficient

ELECTRICAL REQUIREMENTS:

Modules require a source of 115V - 60 cycle I phase power: (208/240/460 60 cycle, 3 phase current if necessary). All wiring to a single junction box

WARRANTY:

This equipment is warranted for a period of one year under its regular contracts attached to the equipment at the time of purchase.

PERFORMANCE:

Velocity 90 F P M \pm 20% produced by air handling system. (meets requirement of Fed. standard-209E & ISO.) Supplies 100 CFM of clean air per square foot of filter area at a minimum of 90 F P M Laminar Air Flow.

TWO STEP AIR FILTRATION:

- A. Pre-filter: Disposable polyester located at intake air grille.
- B. Final Filter: HEPA (High Efficiency Particulate Air) filter, certified by Photometer test method to have a particle efficiency better than 99.97% on all particles 0.3 microns or larger.

Nominal Dimensions	
Model	Dimension "A"
HFM-28	26"
HFM-38	38"
HFM-48	50"
HFM-68	74"
Optional Sizes Available	

HALCO PRODUCTS COMPANY

100 North Gordon Street
 Elk Grove Village, Illinois 60007-1193
 (847) 956-1600 Fax (847) 956-0595
 E-Mail: Info@Halco-Products.com
 Website: www.Halco-Products.com

In line with our policy of continual product improvement, HALCO reserves the right to incorporate and use equipment and material to conform with the latest design of its products, and in keeping with the specifications of this equipment.