



HALCO PRODUCTS COMPANY

100 N. Gordon Street - Elk Grove Village, IL 60007-1193

Tel: 847-956-1600 - Fax: 847-956-0595

E-Mail: Info@Halco-Products.com

Website: www.Halco-Products.com

HALCO
PRODUCT
INFORMATION

200.1000

Air Shower and Air Shower Tunnels

Air Showers offer an effective way to reduce contaminants carried by individuals entering or leaving a controlled area. The Air Shower can solve many of your decontamination problems.



Air Shower tunnels are protected passageways that allow large volumes of personnel to pass into controlled areas.

Air Showers and Tunnels supply concentrated CLASS 100 sterile air flows to lift off contamination while an individual stands in, or walks through, a specially constructed air chamber. Pressurized air streams from nozzles at a velocity between 6,000 and 8,000 feet per minute, which ensures efficient scrubbing action necessary to remove particulate matter. Contaminated air is directed downward through grilles and hollow walls of the Air Shower to the filter. 99.97% of all particles as small as .3 microns are removed.

Halco Air Showers and Air Shower Tunnels are economical to operate, and require a minimum of maintenance.

SPECIAL HALCO AIR SHOWER FEATURES

SOLID STATE ELECTRICAL MICROPROCESSOR SYSTEM CONTROL PANEL INCLUDES:

- Light Switch, audible alarm and alarm reset.
- 4 Line 64 character alpha/numeric LCD display which monitors system function during normal operation and displays menu functions for service and system changes.
- 16 Key membrane keypad for system operation.
 - 4 Number code to turn control on and off
 - 4 Number code to get into systems setup
- **Microprocessor programming capabilities:**
 - Program time of day
 - Program day of the week
 - Program cycle time
 - Program delay unlock time
 - Designate entry and exit doors
 - Program new 4 digit code enter system
 - Program time lock feature
 - Initiate security locking feature with 4 digit code
 - Initiate single direction access feature
- **Microprocessor diagnostic capabilities:**
 - Air shower disabling feature
 - Blower operations check
 - Door switch operations check
 - Door lock operations check
 - Presence sensor/mat switch check
 - Record blower run hours
 - Record air shower cycles
- Interlocking doors (standard), which release automatically with power failure.
- Fluorescent lighting (standard) is contained in the ceiling for less turbulence.
- HEPA Ceiling (optional) for constant laminar flow for added protection.
- Ionized Grid (optional) to eliminate static electricity when required.
- Halco warrants their units for (1) year from date of delivery for defects in workmanship.

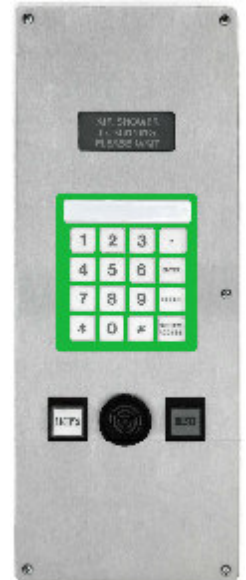

In case of power failure, locks automatically release for exiting. An emergency stop button on each Air Shower sounds on alarm and releases locks for exiting.

HALCO PERSONNEL AIR SHOWERS

Air Shower Tunnels

MODEL#	337	347	357	367	447	457	467	557	567	667	777	13127	13157
(A) Base Sec. HT.*	90	90	90	90	90	90	90	90	90	90	90	90	90
(B) Width	52	52	52	52	58	58	58	64	64	70	84	52	52
(C) Length	44	56	60	72	56	60	72	60	72	72	84	144	180
(D) Blower Box HT.	26	26	30	30	30	30	30	30	30	30	30	30	30
(E) Door Width	30	30	30	30	36	36	36	42	42	48		30	30
(F) Width—ID	35½	35½	35½	35½	41½	41½	41½	47½	47½	53½		35½	35½
(G) Length—ID clear	35	47	51	63	47	51	63	51	63	63		135	171
No. Nozzles	20	20	32	36	32	32	36	32	36	40		60	96
Qty. Blowers	1	1	1	1	1	1	1	1	1	1		3	3
CFM/Blower @ 2" WG	1010	1010	1820	1820	1820	1820	1820	1820	1820	1820		3030	5460
RPM	3600	3600	3600	3600	3600	3600	3600	3600	3600	3600		3600	3600
Wheel Dia.	12½	12½	13½	13½	13½	13½	13½	13½	13½	13½		12½	13½
3 Door Available	No	No	Yes	Yes	No	Yes	Yes	Yes	Yes	Yes		Yes	Yes
Shipping Wt.	1600	1800	1900	2100	1800	2000	2200	2000	2200	2400		5300	5700
Filter size—11½ deep x	18x24	18x24	24x24	24x24	24x24	24x24	24x24	24x24	24x24	24x24		3-18x24	3-24x24
H.P.	2	2	5	5	5	5	5	5	5	5		3-2HP	3-5HP

*HFC Model—for HEPA Filter Ceiling Model add 6" to base section height.

***SPECIAL SIZES ARE ALSO AVAILABLE UPON REQUEST.**

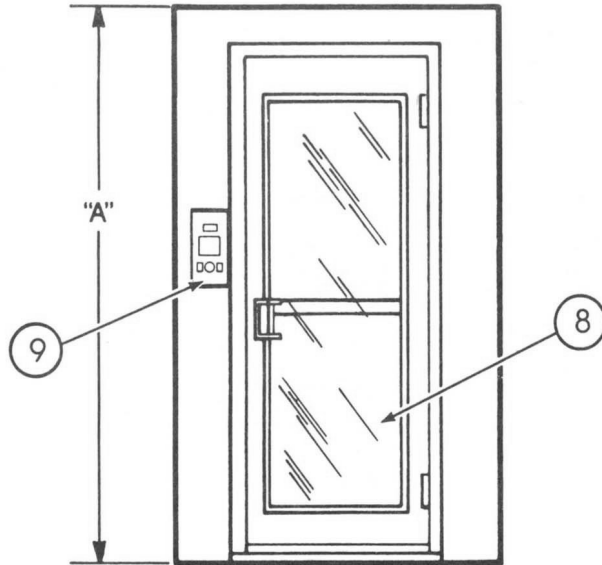
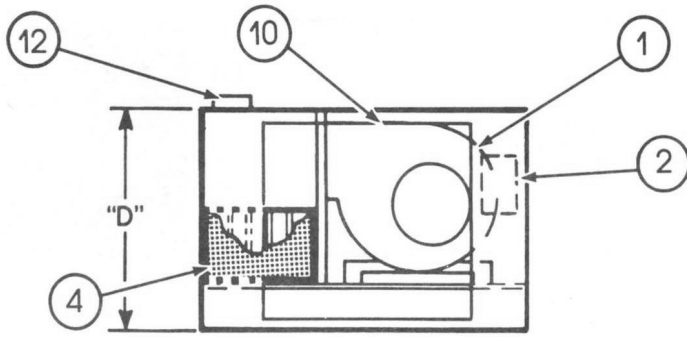

FRONT VIEW ENTRANCE

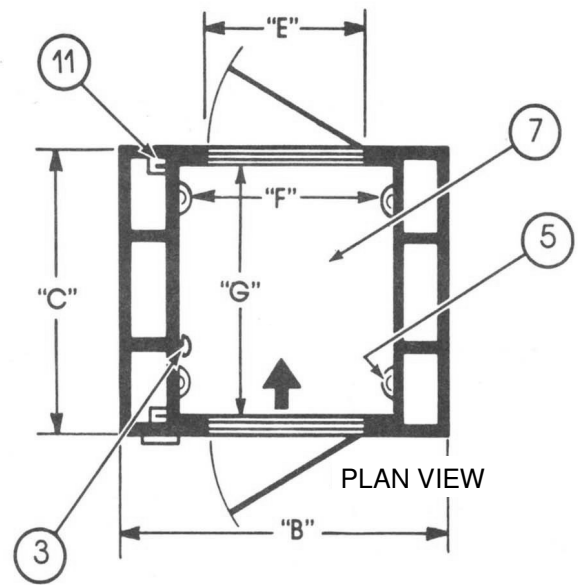

REFLECTED CEILING PLAN

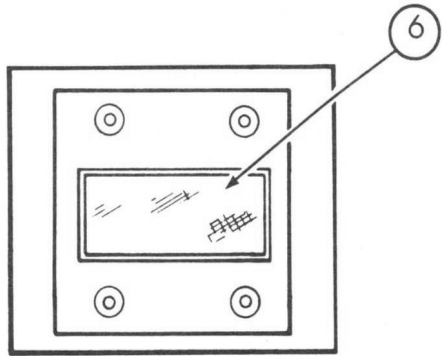

Typical Components

- 1. Motor/Blower assembly
- 2. Power control box.
- 3. Emergency release button
- 4. HEPA filter 99.97% effective on .3 micron particles
- 5. Adjustable nozzles.
- 6. Fluorescent light fixture
- 7. Automatic activated floor switch
- 8. Anodized aluminum doors with plexiglass.
- 9. Microprocessor control panel—On/Off lights—Reset—Alarm.
- 10. Access panels for easy maintenance.
- 11. Electric interlocking chamber.
- 12. Single connection junction box.

AIR SHOWER ELECTRICAL REQUIREMENTS

3 Phase Voltage

HP	MOTOR	BLOWER	VOLTAGE	AMPS
5HP	3N669	4C330	208V	15.3
			230V	13.6
			460V	6.8
2HP	3N667	4C329	208V	7.0
			230V	6.6
			460V	3.3

Construction Options

- ◆ High Density 7/8" particle board, laminated with plastic (Formica or equal) or optional epoxy painted
- ◆ Cold Rolled Steel
- ◆ Stainless Steel

* Other voltages available upon request.

BASIC FLOOR PLANS

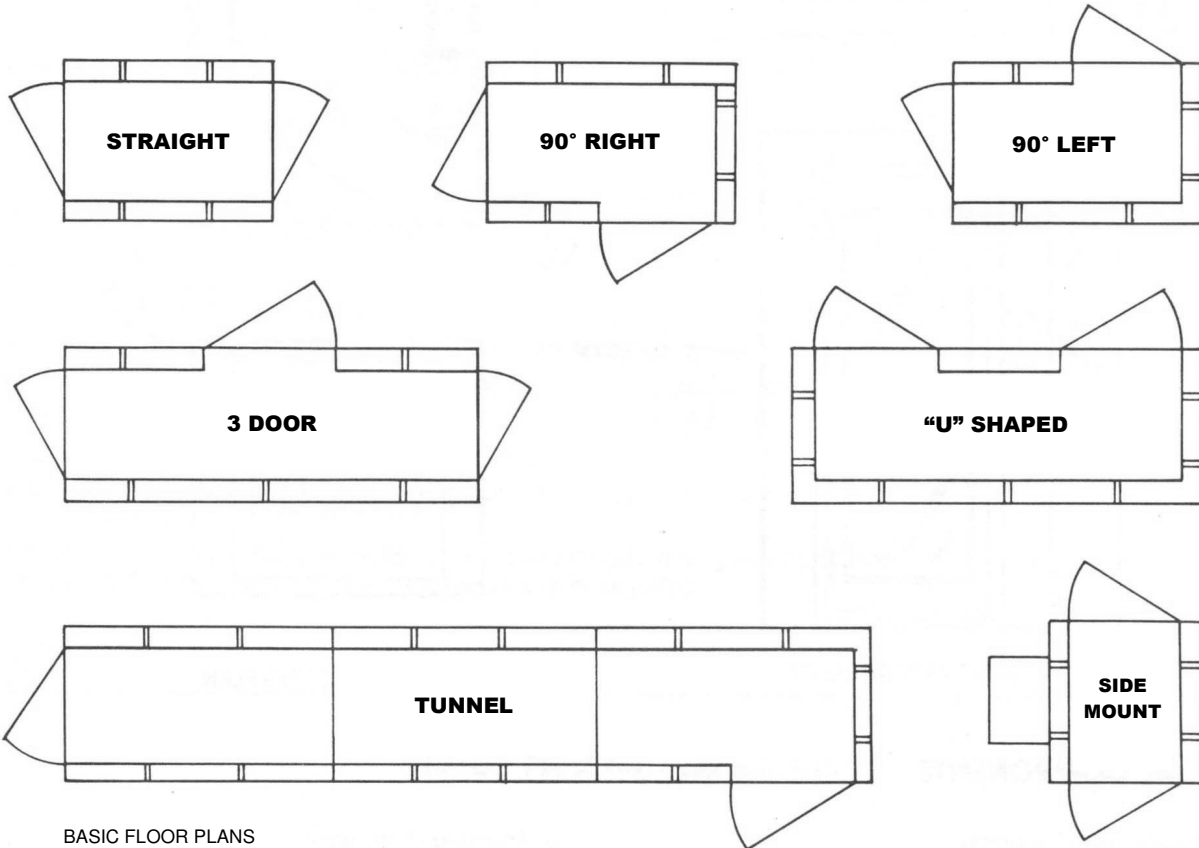

BASIC FLOOR PLANS

NOTE: ANY DOOR MAY BE USED AS AN ENTRANCE OR EXIT

OPTIONAL EQUIPMENT/MODELS

- | | |
|---|--|
| <ul style="list-style-type: none"> • Safety Plate Glass Doors • Magnahelic Gauge HEPA • Magnahelic Gauge Prefilter • Photohelic Gauges with Alarms • Aluminum Grated Floor with Clean Out Pan • Models: | <ul style="list-style-type: none"> • Sprinkler Head • Laminar Ceiling Blower • Auto Bi-part Doors • Proximity Sensor • TEFC or Special Frame Motors |
| <ul style="list-style-type: none"> L - 90° L-Shaped U - U Shaped 3D - Three Door KD - Knock Down Assembly SM - Side Mount HEPA, Motor Blower | <ul style="list-style-type: none"> HFC - HEPA Filter Ceiling IG - Ionized Grid NF - No Floor EXP - Explosion Proof RFR - Raised Floor Return |

***HALCO will custom build to exact specifications.**

HALCO Shower Tunnels are used as downflow booths to remove particulate contamination from personnel entering lunch and break areas, clean rooms & sterile rooms. This is accomplished by putting basic floor plan styles side by side and end to end.

Every Air Shower is under warranty for a period of one year from date of delivery.

Air Showers and Tunnels meet all federal, military and industrial specifications for air showers used for life science, bio medical, pharmaceutical, parenteral drug, micro-electronic, aerospace, precision manufacturing and other applications.

HALCO PRODUCTS COMPANY
 100 North Gordon Street
 Elk Grove Village, Illinois 60007-1193
 (847) 956-1600 Fax (847) 956-0595
 E-Mail: Info@Halco-Products.com
 Website: www.Halco-Products.com

In line with our policy of continual product improvement, HALCO reserves the right to incorporate and use equipment and material to conform with the latest design of its products, and in keeping with the specifications of this equipment.