

REVISIONS			
REV	DESCRIPTION	DATE	APPROVED

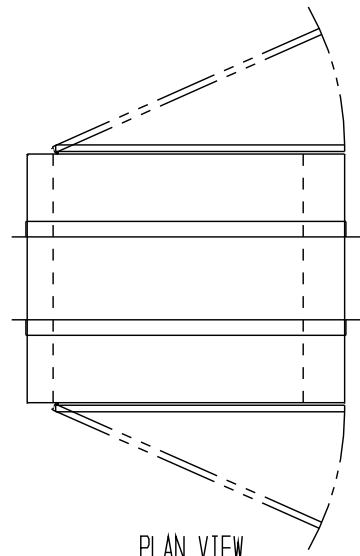

PLAN VIEW

NOTES:

- UNIT FABRICATION TO BE DOUBLE WALL, CONSTRUCTION
- UNIT TO BE CONSTRUCTED OF 20 GA. 304 STAINLESS STEEL WITH #4 FINISH
- DOORS TO BE CONSTRUCTED OF 20 GA. 304 STAINLESS STEEL WITH 1/4" THK. CLEAR ACRYLIC INSERTS, BLACK POWDER COATED PIN HINGES AND STAINLESS STEEL "D" HANDLE
- UNIT TO BE SUPPLIED WITH 1 1/2" X 1 1/2" X 16 GA. 304 STAINLESS STEEL MOUNTING ANGLE (TO BE FIELD INSTALLED)
- UNIT TO HAVE A MECHANICAL DOOR INTERLOCK SYSTEM
- ROUGH OPENING TO BE 1/4" LARGER THAN OUTSIDE DIMENSIONS OF UNIT

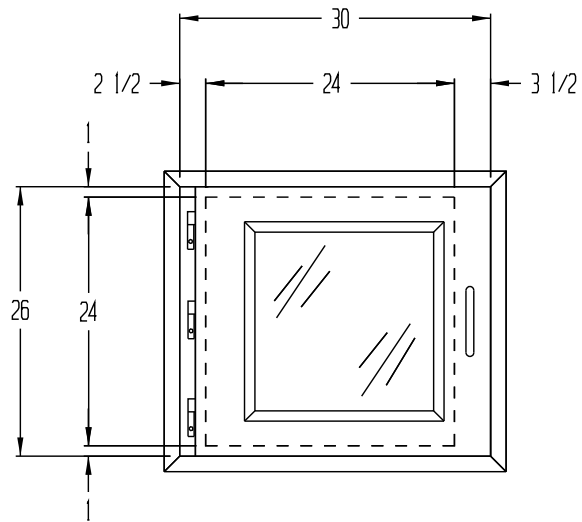

FRONT VIEW

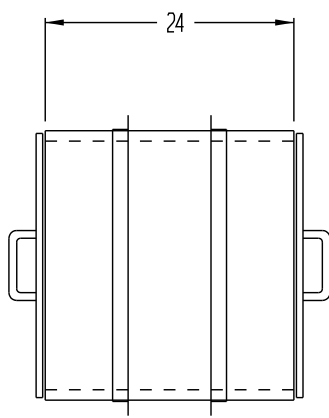

SIDE VIEW

DRAWN FOR		HALCO PRODUCTS CO.			
		100 NO. GORDON STREET ELK GROVE, IL. 60007			
		TITLE PT2424-24 MI/SS			
DRAWN BY	TM	SIZE	JOB NO.	DWG NO.	1516825AA
APPROVED BY		SCALE	NONE	DATE	9-9-11
				SHEET	