

REAR VIEW

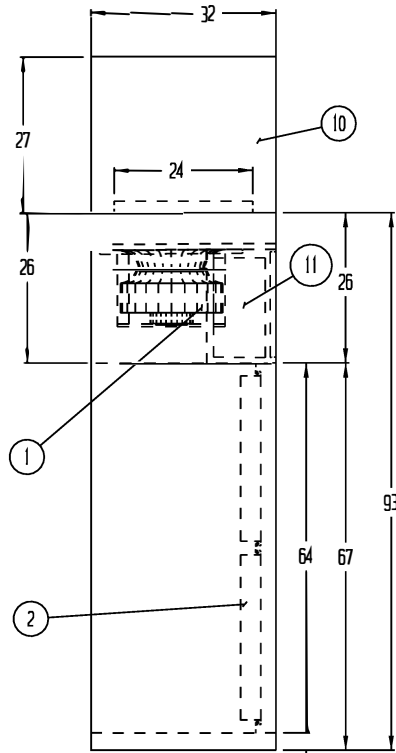

LEFT SIDE VIEW

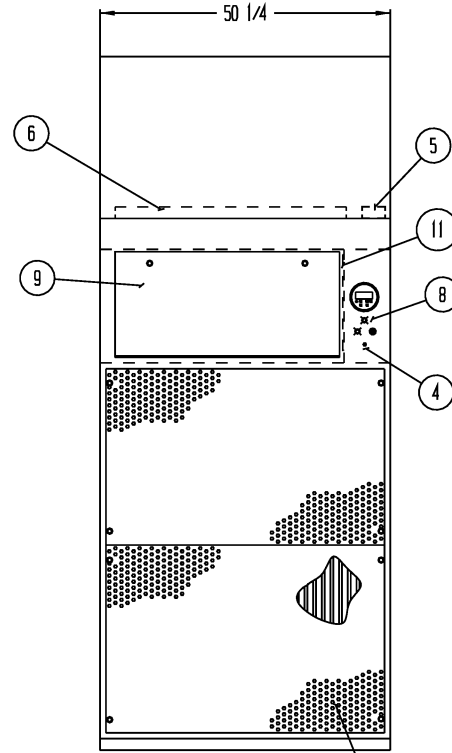

FRONT VIEW

REVISIONS			
REV	DESCRIPTION	DATE	APPROVED

- ① 1 EA. GKM450-CIW.138.5 DIRECT DRIVE ECM IMPELLER, 800W, 460 VOLT, 60 HZ, 1.8 FLA EA, CAPABLE OF PRODUCING 2400 CFM AT 2" SP
- ② 2 EA. 30 X 48 X 3 1/2" ALUMINUM FRAMED, GEL SEALED, HEPA FILTER, 99.99% EFFICIENT ON 0.3 MICRON SIZE PARTICLES (REPLACABLE FROM FRONT)
- ③ STAINLESS STEEL DIFFUSER GRILLES, PERFORATED WITH 1/8" DIA. HOLES ON 3/16" STAGGERED CENTERS, 40% OPEN AREA, ATTACHED W/ 1/4 TURN FASTENERS
- ④ BLOWER SPEED POTENTIOMETER
- ⑤ ELECTRICAL JUNCTION BOX FOR CUSTOMER CONNECTION
- ⑥ TOP DUCT CONNECTION FOR INLET AIR, 24" X 40" X 2"
- ⑦ RETURN FLANGES FOR WALL INTERFACE
- ⑧ ELECTRICAL ENCLOSURE WITH PHOTOHELIC PRESSURE GAUGE, HIGH/LOW SETPOINTS, PILOT LIGHT ALARM, AUDIBLE ALARM W/ SILENCE BUTTON, INTERNAL POWER SUPPLY AND BREAKERS
- ⑨ HINGED FRONT MOTOR ACCESS PANEL
- ⑩ 27" HIGH SS FASCIA FOR FRONT & SIDES, SHIPPED LOOSE
- ⑪ INTERNAL ELECTRICAL ACCESS PANEL

NOTES:

- CONSTRUCTION TO BE 16 GA. TYPE 304 STAINLESS STEEL WITH A #4 FINISH
- HEPA FILTERS TO BE FRONT LOADED
- ELECTRICAL WIRING TO CONFORM TO LATEST NEC STANDARDS
- UNIT TO MEET ISO STANDARD 14644-1 (FED. STD. 209B & 209E)
- ELECTRICAL REQUIREMENTS: 460 VOLT, 60 HZ, 2.7 FLA, 3 PHASE
- BLOWERS SIZED TO PRODUCE AN AIR FLOW OF 90 FPM +/- 20%

(1) UNIT REQUIRED AS SHOWN

DRAWN FOR		HALCO PRODUCTS COMPANY, INC. 100 NO. GORDON STREET ELK GROVE, IL. 60007			
DRAWN BY	TM	SIZE	JOB NO. 13602-1	DRG NO. 141865288	REV 8
APPROVED BY		SCALE	1/2"=1'-0"	DATE 4-21-15	REF 13335