

REVISIONS			
REV	DESCRIPTION	DATE	APPROVED

NOTE:

- HEPA FILTER REPLACED FROM BELOW WITHOUT DISTURBING CEILING OR HOUSING
- ELECTRICAL TO MEET LATEST NEC CODES
- UNIT TO MEET ISO 14644-1 (FEDERAL STANDARD 209E)
- UNIT WEIGHT 85 LBS.
- ELECTRICAL REQUIREMENTS 115 VOLT, 1 PHASE, 60 HZ., 4.6 FLA

- ① 1 EA. 9-9AT DIRECT DRIVE BLOWER WITH 1/3 H.P. MOTOR. CAPABLE OF PRODUCING 600 CFM
- ② 1 EA. 19-3/4 X 43-3/4 X 3-1/2" ALUMINUM FRAMED HEPA FILTER, 99.99% EFFECTIVE ON PARTICLES OF .3 MICRONS. GASKET SEAL
- ③ 1 EA. 12" DIA STARTER COLLAR
- ④ ELECTRONIC VARIABLE SPEED CONTROL
- ⑤ 4 EA. EYEBOLT HANGING SUPPORTS
- ⑥ ANODIZED ALUMINUM PROTECTIVE GRILL WITH 1/8" DIA. HOLE ON 3/16" STAGGERED CENTERS ACCOUNTING FOR AN OPEN AREA OF 40%

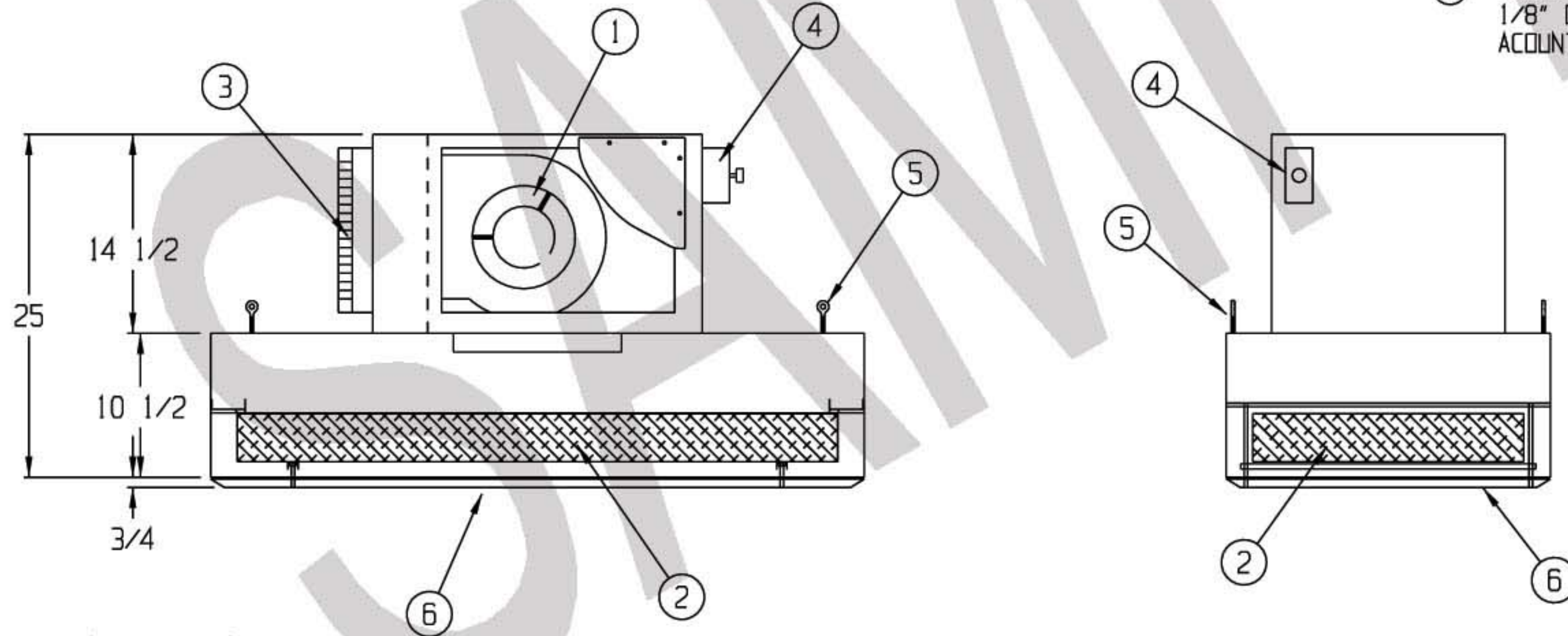
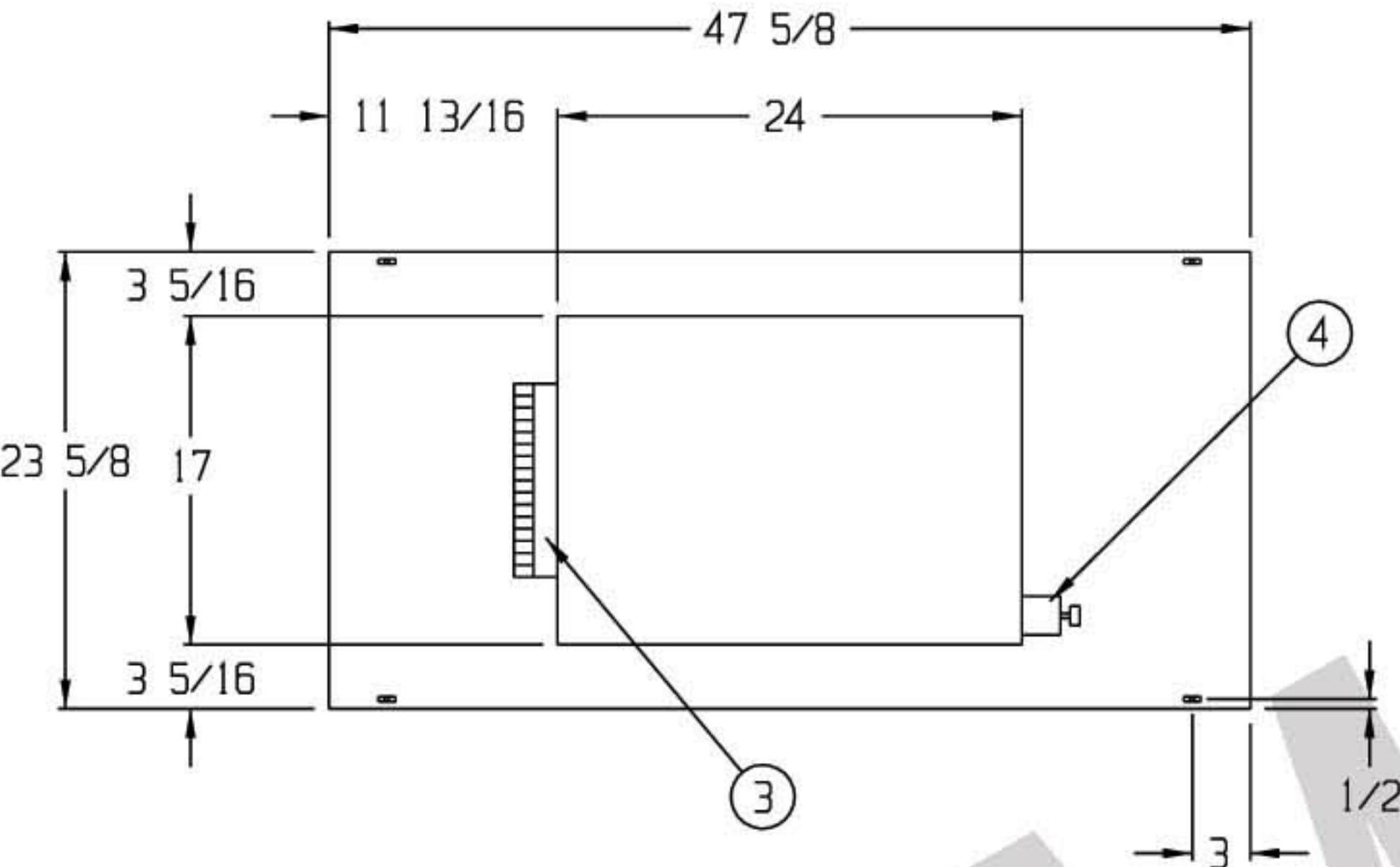

CONSTRUCTION:

- MODULE CONSTRUCTED OF 14 GA 3003-H14 MILL ALUMINUM
- UNIT ASSEMBLED WITH INSIDE TURNED FLANGES WHICH ARE CAULKED AND RIVITED

DRAWN FOR		<b>HALCO PRODUCTS CO.</b>		
		100 NO. GORDON STREET ELK GROVE, IL. 60007		
		TITLE FT2448MD/RF/AL		
DRAWN BY	TM	SIZE	JOB NO. _____	ENG. NO. 1715889A0
APPROVED BY		SCALE 1/2" = 1'-0"	DATE 10-19-09	REVISION SHEET