

REVISIONS			
REV	DESCRIPTION	DATE	APPROVED

NOTES:

- UNIT TO BE CONSTRUCTED OF 16 GA. AND 14 GA. ANODIZED ALUMINUM
- ELECTRICAL WIRING TO CONFORM TO NEC STANDARDS
- UNIT TO MEET ISO STANDARD 14644-1
- TOTAL CLEAN AIR CAPACITY, 600 CFM
- ALL HEPA FILTERS TO BE PSL TESTED
- CUSTOMER TO SUPPLY 115 VOLT, 1 PHASE, 60 CYCLE

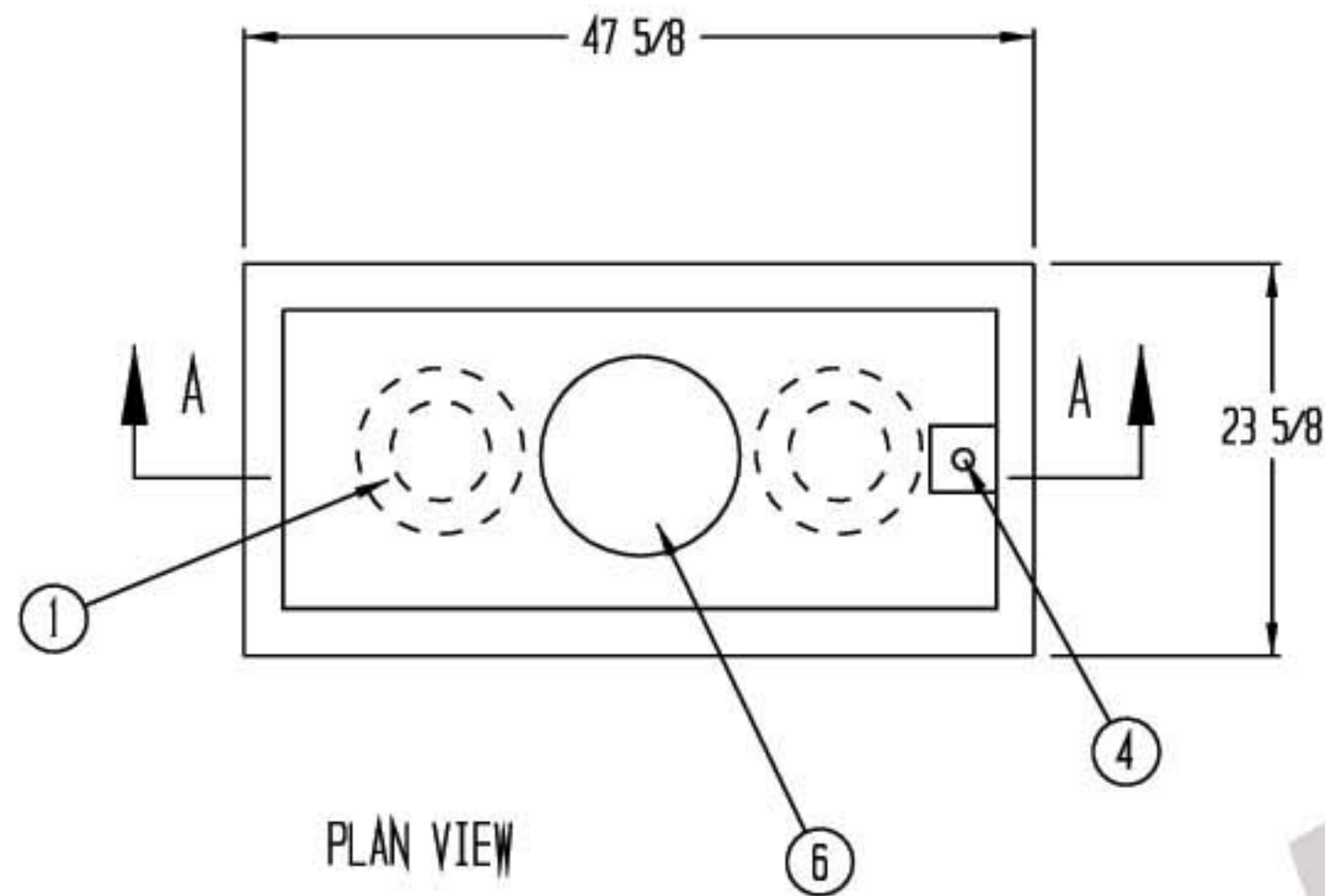

PLAN VIEW

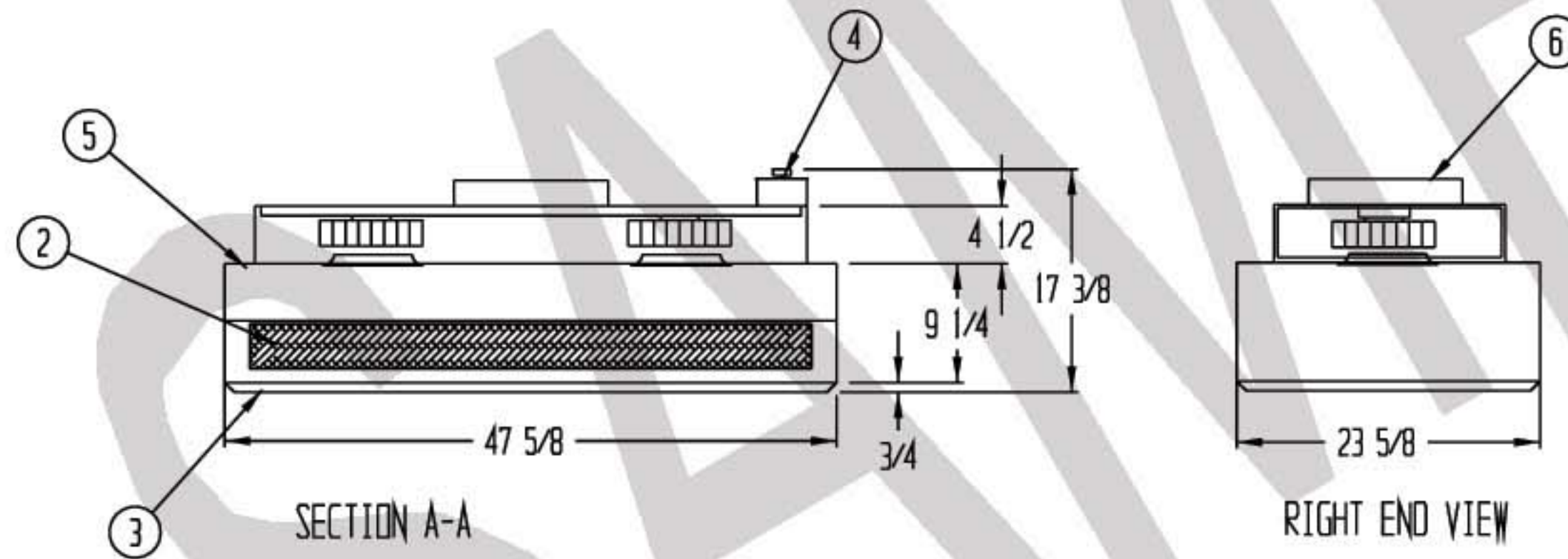

SECTION A-A

RIGHT END VIEW

LEGEND:

- ① 2 EA. BACKWARD CURVED IMPELLER, 115V, 60 HZ, 100W
- ② 1 EA. 19 3/4 X 43 3/4 X 3 1/2" THK. HEPA FILTER, 99.99% EFFICIENT ON PARTICLE OF 0.3 MICRON SIZE
- ③ 40% OPEN ANODIZED ALUMINUM PERFORATED GRILL
- ④ ELECTRICAL JUNCTION BOX WITH ELECTRONIC SPEED CONTROL
- ⑤ SOUND ABSORBING INSULATION
- ⑥ 12" DUCT CONNECTION

DRAWN FOR		<b>HALCO PRODUCTS CO.</b> 100 NO. GORDON STREET ELK GROVE, IL. 60007		
		TITLE FT2448-LD/AL/RF/D12		
DRAWN BY	TM	SIZE	JOB NO.	ENG. NO.
APPROVED BY		SCALE	1/2" = 1'-0"	DATE
			1715891A0	10-19-09
			SHEET	REV