

REVISIONS			
REV	DESCRIPTION	DATE	APPROVED

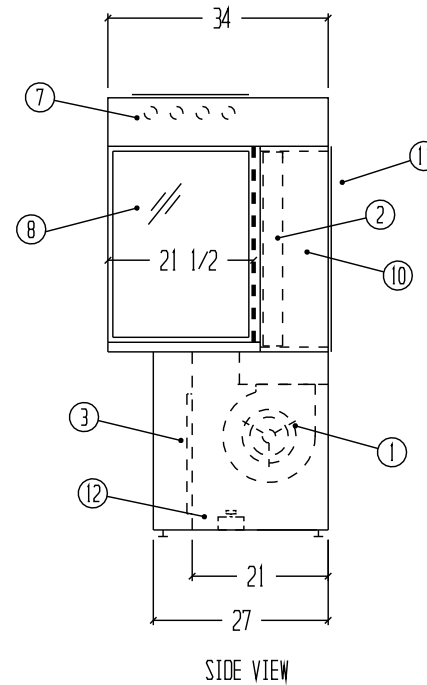
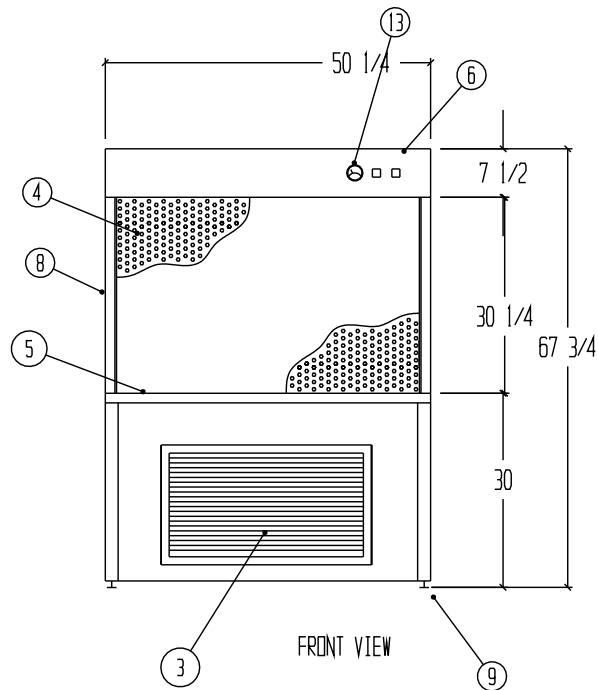

- ① 1 EA. DD10-10AT DIRECT DRIVE BLOWER WITH 1/3 HP. MOTOR 115 VOLT/ 1 PHASE/ 60 CYCLE/ 4.7 FLA, CAPABLE OF PRODUCING 1000 CFM EACH AT 1" S.P.
- ② 1 EA. 30" X 48" X 3 1/2" HEPA FILTER, 99.99% EFFECTIVE ON PARTICLES OF 0.3 MICRONS IN SIZE
- ③ 1 EA. 30" X 16" ANODIZED ALUMINUM PRE-FILTER GRILLES WITH 1" THK. 35% EFFICIENT DISPOSABLE PRE-FILTERS
- ④ ANODIZED ALUMINUM HEPA FILTER DISCHARGE GRILLE
- ⑤ WHITE PLASTIC LAMINATE WORK SURFACE
- ⑥ CONTROL/LIGHT SWITCHES
- ⑦ FLUORESCENT LIGHT FIXTURE WITH FLUORESCENT TUBES CAPABLE OF PRODUCING 100 F.C.
- ⑧ CLEAR LEXAN SIDE PANELS
- ⑨ LEG LEVELERS
- ⑩ PLENUM AREA
- ⑪ REAR ACCESS PANEL FOR HEPA FILTER
- ⑫ ELECTRONIC SPEED CONTROL
- ⑬ MINIHELIC PRESSURE GAUGE FOR HEPA FILTER

NOTES:

- CONSTRUCTION TO BE 16 GA. GALVANNEALED STEEL WHITE EPOXY PAINTED
- WORK SURFACE TO BE WHITE PLASTIC LAMINATE
- UNIT TO MEET ISO STANDARD 14644-1 (FED. STD. 209E)
- ELECTRICAL WIRING TO CONFORM TO LATEST N.E.C. STANDARDS

DRAWN FOR		HALCO PRODUCTS CO.			
		100 NO. GORDON STREET ELK GROVE, IL. 60007			
		TITLE HORIZONTAL CONSOLE - AC4302-ST			
DRAWN BY	TM	SIZE	JOB NO. 13206	DWG NO. 1417839A0	REV
APPROVED BY		SCALE 3/4"=1'-0"	DATE 9-3-13	SHEET	